

### 3.POWER CONNECTION

**NOTICE:**

- ✧ Cool white and warm white lights can be connected to DC 12V or AC 12V
- ✧ RGB lights only can be connected to DC 12V.
- ✧ Power: 6W

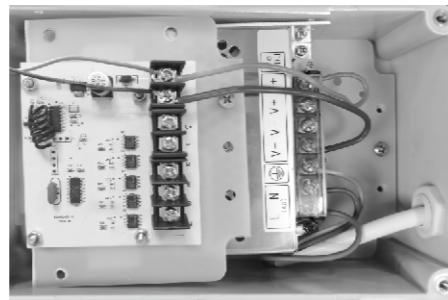
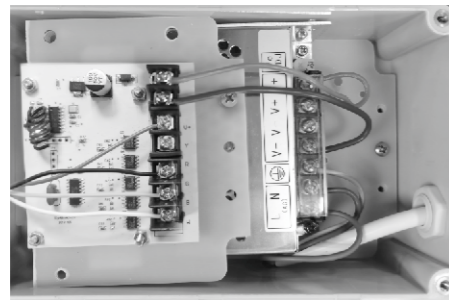
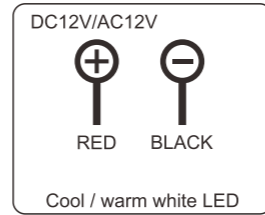
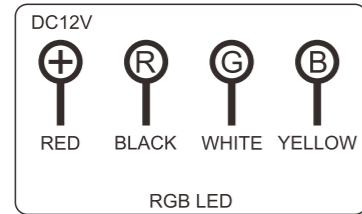

### 4.MAINTENANCE AND REPLACEMENT

**ATTENTION**

Always disconnect power to the pool light at the circuit breaker before servicing the light. Failure to do so could result in electrical shock, which may cause serious damages to swimmers, installers or others.

**WARNING**

The replacement lamp must use the same model and wattage. Failure to do so could result in electrical shock, which may cause serious damages to swimmers, installers or others.

- (1) When repairing the light, disconnect the main power switch or circuit switch, and underwater light's switch.
- (2) Prepare the light you need to replace, and ensure the new lamp is the same model and characteristics as the one being replaced.
- (3) Rotate to the left (counterclockwise) to remove the damaged lamp body.
- (4) Reconnect the new lamp to the wire (note that the colored wires cannot be connected to the wrong position, otherwise the lamp body cannot be normally energized), and waterproof treatment should be done at the end of the wire connection.
- (5) Fill the water until the underwater light is fully immersed in the pool, then turn on the main switch and circuit switch to check the new light for proper operation.
- (6) During use, the leakage protection switch must be inspected at least once a month to ensure that the leakage switch is working properly.
- (7) During use, personnel should not be allowed to step on the lamp body to avoid accidental damage and loss caused by the deformation of the lamp body and the breakage of the lamp bead.

## WL-LA-LED SERIES UNDERWATER LIGHT OPERATION MANUAL

WL-LA-LED063JTB  
 WL-LA-LED063JTW  
 WL-LA-LED063JTC



III IP68 0.6m  
 ISO9001:2008 CE

**CAUTION**

**RISK OF ELECTRICAL SHOCK OR ELECTROCUTION**

This underwater light must be installed by a licensed or certified electrician in accordance with the nation Electrical Code and all application local codes and ordinances. Improper installation will create an electrical hazard which could result in death or serious injury to pool users, installer or other due to electrical shocks, and may also cause damage to property. Read and follow the specific instruction below.

**WARNING**

Before installing this underwater light, read and follow all warning notice and instructions accompanying with this light. Otherwise it will result in severe injury, death or property damage.

**ATTENTION**

**IMPORTANT NOTICE**

This manual contains important information about the installation, operation and safe use of this product. This information should be given should be given to the owner/operator of this equipment.

## 1.PRODUCTION DESCRIPTION

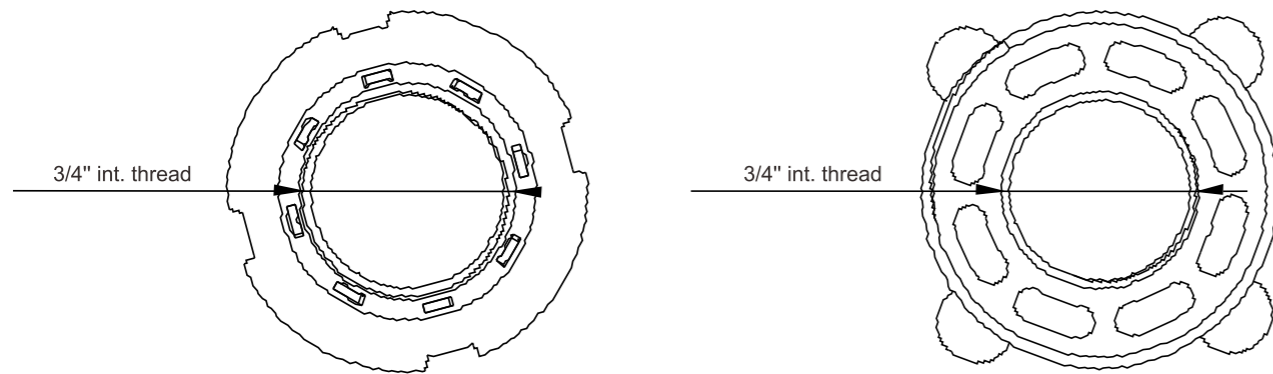
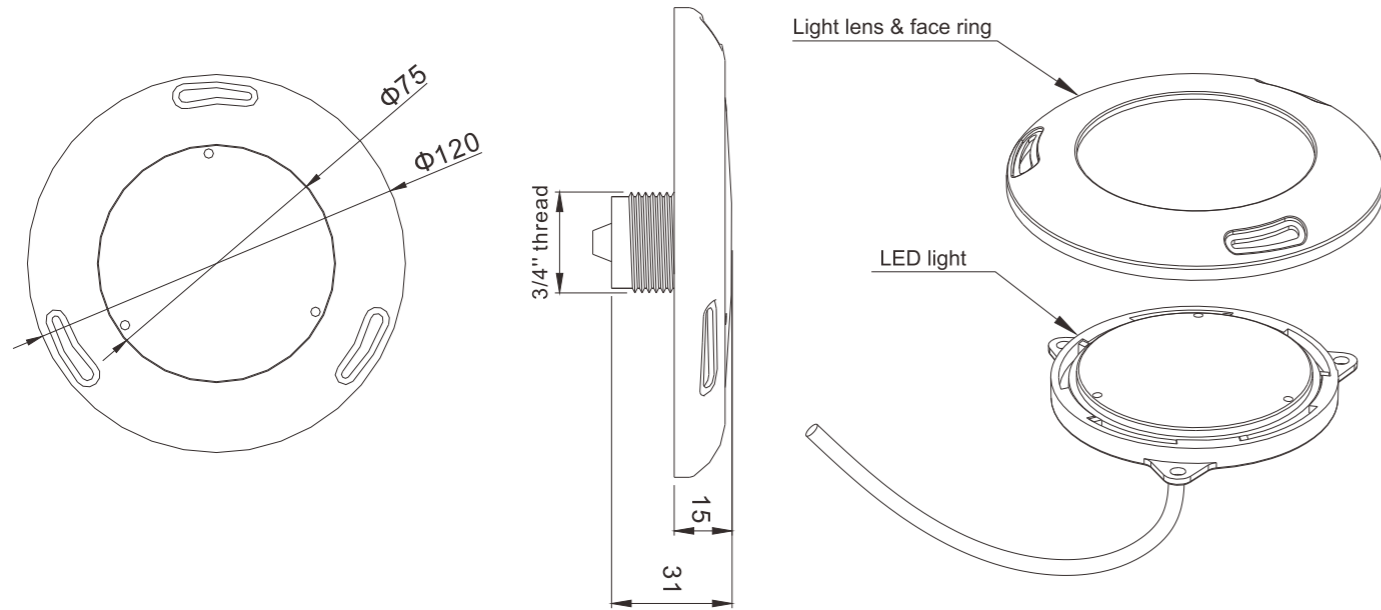

**1.5" plugged fitting**

**1.5" thread fitting**

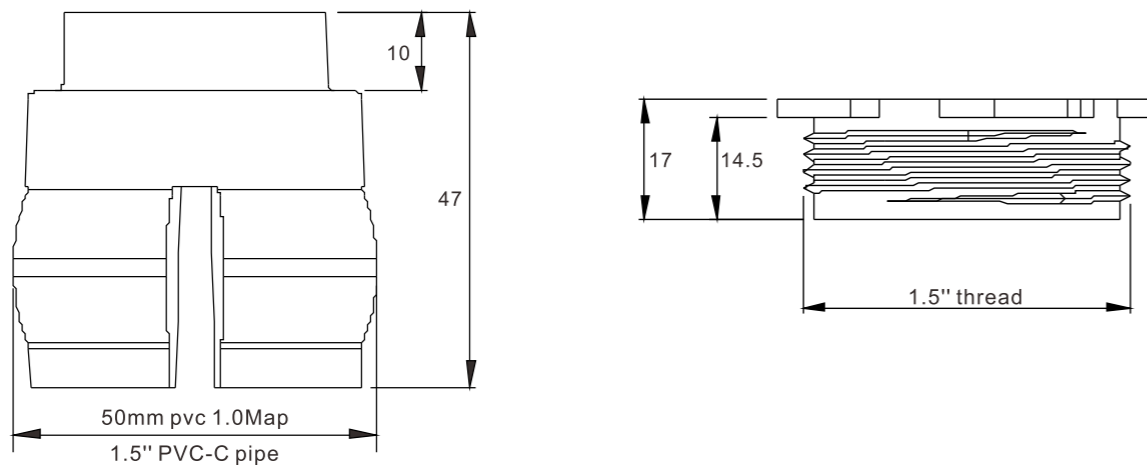

## 2.INSTALLATION

### A.Preparatory step which must be completed by the electrician before lights installed.

- (1). Ensure that the pool meets the requirements of the current National Electrical Code and all local codes and ordinance. A licensed or certified electrician must install the electrical system to meet or exceed those requirements before the underwater light is installed. Some of the requirement of the National Electrical code are listed below.
- (2)The lighting circuit must have a Ground Fault Circuit Interrupter (GFCI), and must have an appropriately rated circuit breaker, and its ground resistance should be no more than 0.1Ω, and the working voltage should be no more than 12V.
- (3)The junction box (or 12 voltage models, the low voltage transformer) must be located at least 30.5cm above the water level, 10cm from the ground and at least 120cm from the edge of the pool. See figure 1.

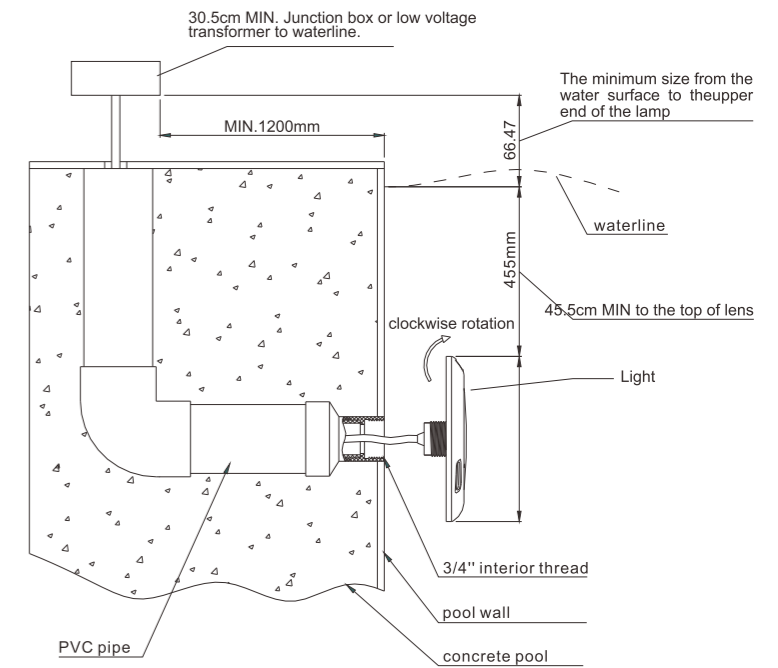
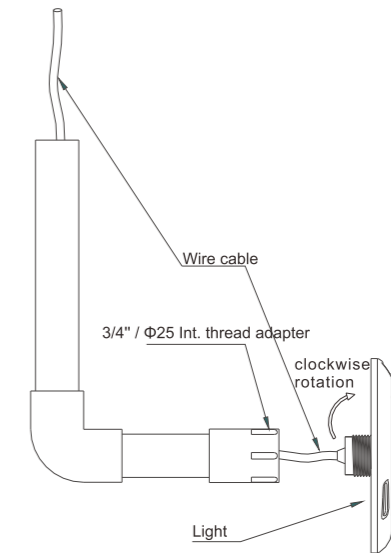

**Figure 1**

- (4). The light must be properly installed so that the top edge of the underwater light's lens is at least 45.5cm below the surface of the water in the pool. The light must match with joint shell. To be certain that the pool's electrical system meets all applicable requirements, you should also consult the local building department.

### B.The following are steps to perform after the electrical system requirements met.

- (1). As shown in Figure 2, first glue the 3/4" interior thread adapter to the pre-embedded water pipe, and turn the lamp clockwise and tighten to the adapter.
- (2). As shown in Figure 3, first push the 1.5" plugged fitting into the pre-embedded water pipe, and turn the lamp clockwise and tighten to the 1.5" plugged fitting.
- (3). As shown in Figure 4, first glue the universal 1.5" pool fitting to the pre-embedded water pipe, then screw well the 1.5" thread fitting, and turn the lamp clockwise and tighten to the 1.5" thread fitting.



**Figure 2**

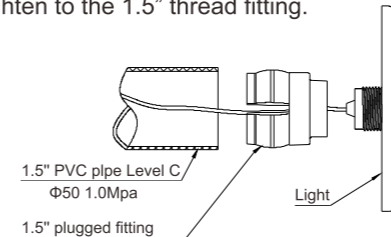

**Figure 3**

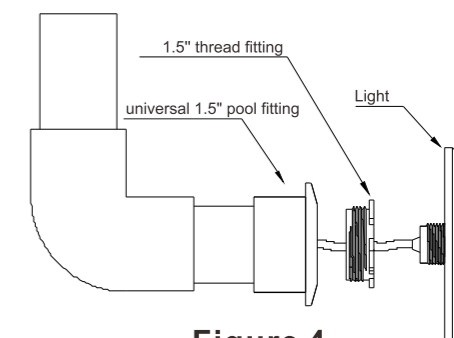

**Figure 4**