

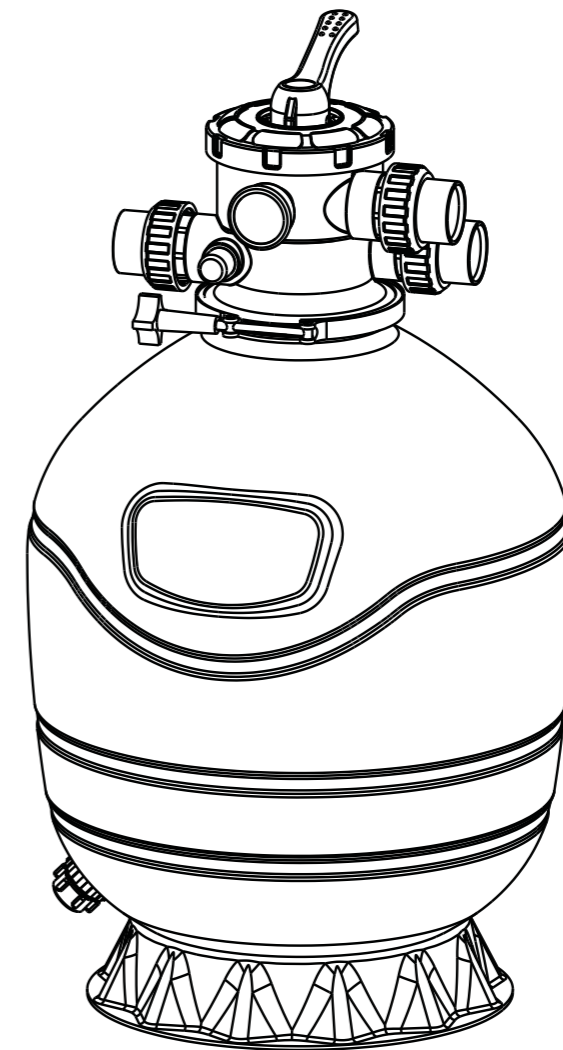

# “WL-SDG” SERIES TOP MOUNT SAND FILTERS

OWNER'S MANUAL

[ WL-SDG-17 WL-SDG-20 WL-SDG-24 WL-SDG-26 ]



## 1 FUNCTION

The filter uses special filter sand to remove dirt particles from pool water. The filter sand is loaded into the filter tank and functions as the permanent dirt removing media. When the control valve is in the FILTER position, the pool water which contains suspended dirt particles, is pumped through the piping system and is automatically directed by the patented filter control valve to the top of the filter tank. As the pool water is pumped through the filter, dirt particles are trapped by the sand bed, and filtered out. The cleaned Pool water is returned from the bottom of the filter tank, through the control valve and back to the pool through the piping system. This entire sequence is continuous and automatic and provides for total recirculation of pool water through the filter and piping system.

After a period of time the accumulated dirt in the filter causes a resistance to the flow, and make it diminishes. This means it is time to clean your filter. With the control valve in the BACKWASH position, the water flow is automatically reversed through the filter so that it is directed to the bottom of the tank, up through the sand, flushing the previously trapped dirt and debris out the waste line. Once the filter is back-washed of dirt, set control valve to RINSE position and run pump for about 1/2 to 1 minute, and then to resume normal filtering.



NOTE

Stop the pump before changing valve position!



NOTE

Please read and follow this MANUAL before install and use the filter!

## 2 DIMENSIONS

	SDG-17	SDG-20	SDG-24	SDG-26
Φ D(mm)	425	500	600	650
H(mm)	767	890	983	1028
B(mm)	75	75	75	90
A(mm)	526	650	743	787
Φ P(mm)	390	390	390	560
N(mm)	579	702	795	839
M(mm)	635	758	850	895

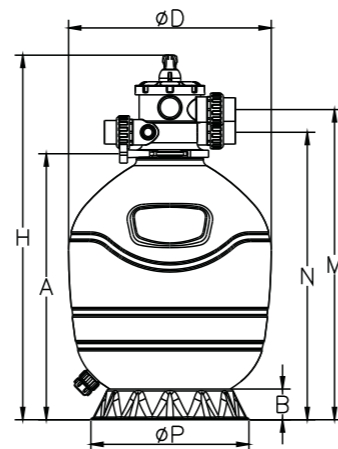

NOTE

It is recommended to use adapter unions. Maintenance works and replacement are also easier by using adapter unions.

## 2. FUNCTION AND INSTALLATION SCHEME

### I. Filtration of medium (i.e. water)

Pool → pump → valve (to filter) → filter → valve (from filter) → pool

### III. No circulation

Do not operate pump.

Pool → pump → valve

### V. Recirculation of fluid without filter (by pass filter)

Pool → pump → valve → pool

### II. Drainage of pool with pump

Pool → pump → valve → canal

### IV. Cleaning of filter medium (i.e. sand) in upstream (reserved flow in filter)

Pool → pump → valve (from filter) → filter → valve (to filter) → waste

### VI. Cleaning of filter medium (i.e. sand) after backwash

Pool → pump → valve (to filter) → filter → valve (from filter) → waste

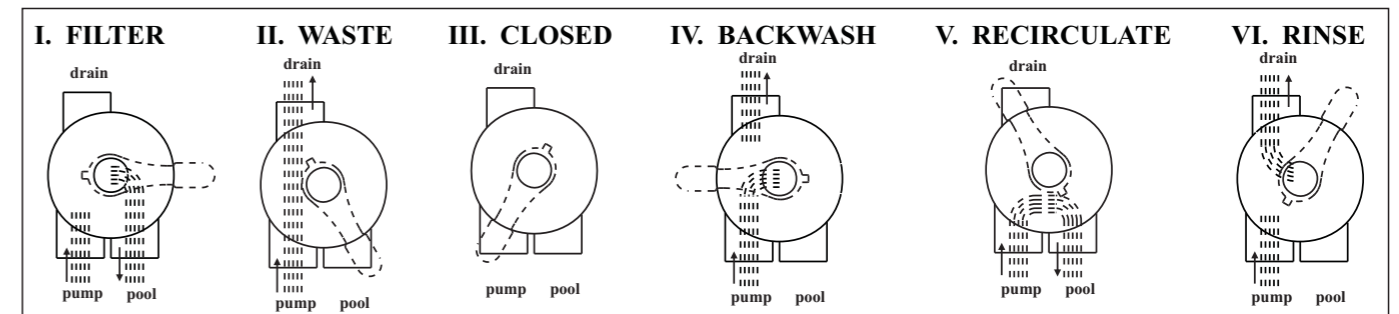

## 7 WARNING



NOTE

1. This filter operates under high pressure. When any part of the circulating system (e.g., clamp, pump, filter, valves, etc.) is serviced, air can enter the system and become pressurized. Pressurized air can cause the lid or valve to be blown off which can result in severe injury, death, or property damage. Do not unscrew screws of flange clamp while filter operating.
2. Turn pump off before changing valve position.
3. To prevent damage to the pump and for proper operation of the system, Clean pump strainer and skimmer baskets regularly.

- d. Connect pump to control valve opening marked PUMP. After connections are made, tighten valve flange clamps with screwdriver, tap around clamp with screwdriver handle to help seat valve flange clamp.
- 4. Make return to pool pipe connection to control valve opening marked RETURN and complete other necessary plumbing connections, suction lines to pump, waste, etc.
- 5. Make electrical connections to pump following pump instructions.
- 6. To prevent water leakage, be sure all pipe connections are tight.

### 5 INSTALL / START-UP OF FILTER

- 1. Be sure correct amount of filter sand is in tank and that all connections have been made and secured.
- 2. Push down control valve handle and rotate to BACKWASH position. (To prevent damage to control valve seal, always push down handle before turning.)
- 3. Start pump according to pump instructions (be sure all suction and return lines are open), allowing the filter tank to fill with water. Once water is flowing out of the filter, remove any impurities or fine sand particles in the sand media.
- 4. Stop the pump and set valve to RINSE position. Start pump and operate until water in sight glass is clear, about 1/2 to 1 minute. Stop the pump and set valve to FILTER position and then restart pump. The filter is now operating in the normal filter mode, filtering dirt particles from the pool water.
- 5. Adjust pool suction and return valves to achieve desired flow. Check system and filter for water leaks and tighten connections, bolts, nuts, as required.
- 6. Note the initial pressure gauge reading when the filter is clean. (It will vary from each pool depending upon the pump and general piping system.) As the filter removes dirt and impurities from the pool water, the accumulation in the filter will cause the pressure to rise and flow to diminish. When the pressure gauge reading is 150KPa/1.5Kg/cm<sup>2</sup> higher than the initial "clean" pressure you noted, it is time to backwash the filter (see BACKWASH under filter and control valve functions).



During initial clean-up of the pool water it may be necessary to backwash frequently due to the unusually heavy initial dirt load in the water.

NOTE

### 6 TECHNICAL APPENDIX

#### 1. INSTALLATION INSTRUCTIONS

The installation of the valve is carried out by screwing or slipping in, of the available connections according to the installation scheme.



NOTE

Maximum working pressure: 50psi.  
Maximum water temperature: 50 °C.

### 3 REPLACEMENT PARTS OF FILTER

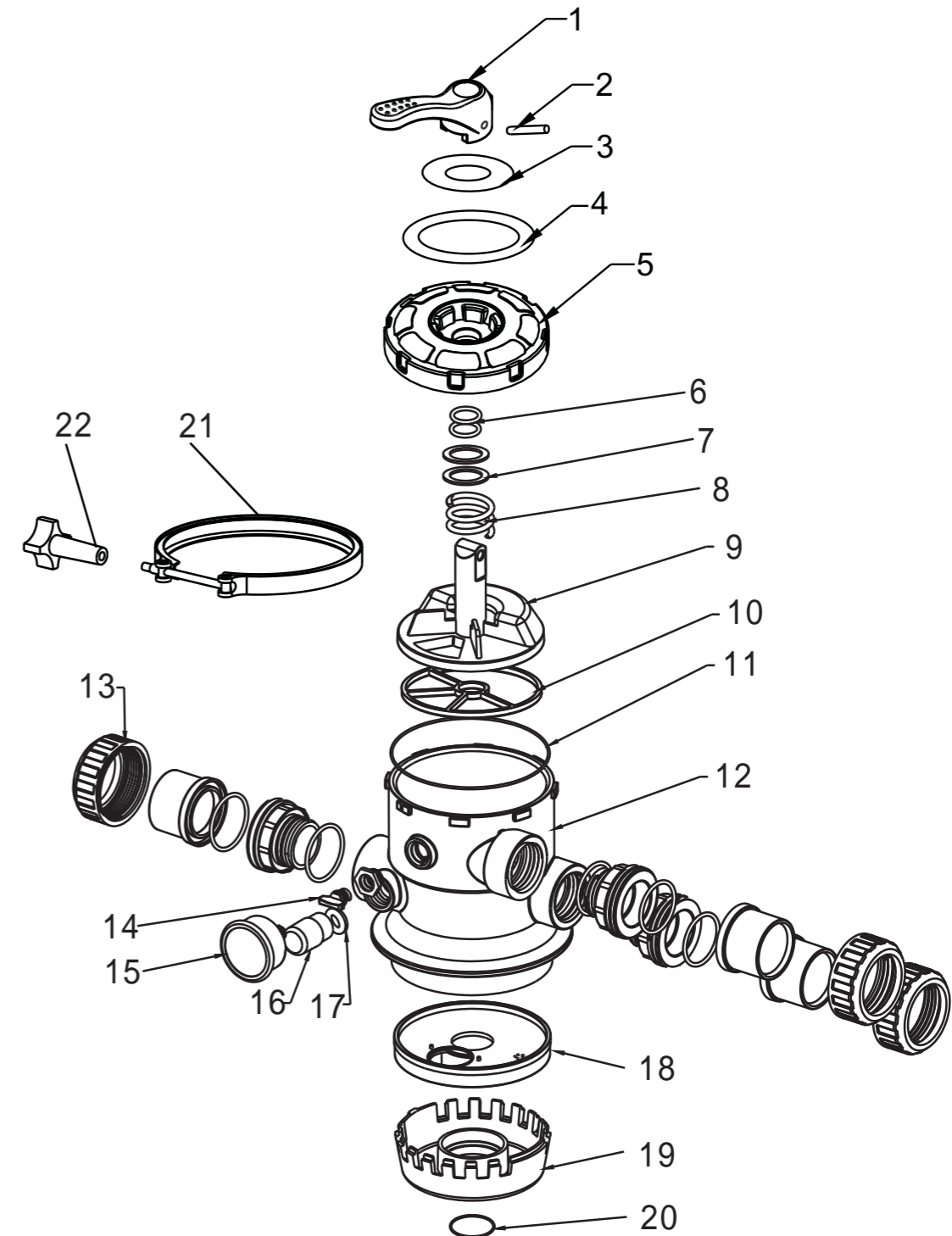

ID	DESCRIPTION	QTY	ID	DESCRIPTION	QTY
1	Handle	1	13	Bulkhead assy	3
2	Screw-handle	1	14	Plug	1
3	Washer-B	1	15	Pressure gauge	1
4	Function point-out panel	1	16	Sight glass	1
5	Lid assy	1	17	Sight glass o-ring	1
6	Washer-plastic	2	18	Rotor	1
7	Washer-S	2	19	Orer drain,diffuser	1
8	Spring	1	20	O-ring,filter	1
9	Rotor	1	21	Neck ring clamp	1
10	Gasket	1	22	Screw-clip	1
11	O-ring,lid	1			
12	Body-diffuser assy	1			

ID	DESCRIPTION	QTY	ID	DESCRIPTION	QTY
1	Multiport valve 1 5 "	1	5	Center pipe	1
2	Clip -Stainless steel	1	6	Lateral Assembly	1
	Lock nut	1	7	Lateral	8
3	Gasket of Flange	1	8	Support pipe	1
4	Tank 17 "	1	9	Drain	1
	Tank 20 "	1	10	Filter Support Stand	1
	Tank 24 "	1			
	Tank 26 "				

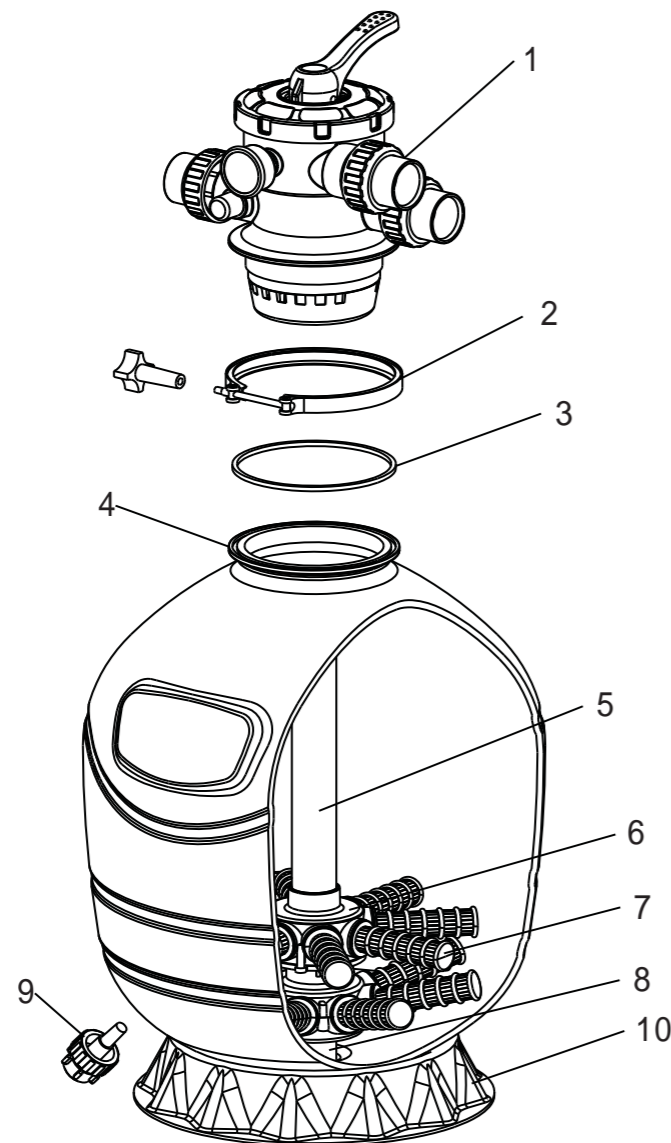

## 4 INSTALLATION

Only simple tools (screwdriver and wrenches), plus pipe sealant for plastic adapters, are required to install and service the filter.

1. The filter should be placed on a reasonably level surface and provide adequate drainage. Position the filter so that the piping connections, control valve are convenient and accessible for operation and service, The filter should be placed as close to the pool as possible to reduce line loss from pipe friction.
2. Loading the sand media. Filter sand media is loaded through the top opening of the filter.
  - a. Loosen flange clamp and remove filter control valve (if previously installed).
  - b. Cap internal pipe with plastic cap to prevent sand from entering it.
  - c. We recommend filling tank approximately half full of water to provide a cushion effect when the filter sand is poured in. This helps protect the under-drain laterals from excessive shock.
  - d. Carefully pour in correct amount and grade of filter sand. (Be sure center pipe remains centered in opening.) Sand surface should be leveled and up to about the middle of the filter tank. Remove plastic cap from internal pipe.
3. Assemble filter control valve to filter tank.
  - a. Insert filter control valve (with O'ring in place) into the tank neck, beware that the center pipe slips into the hole in the bottom of the valve.
  - b. Place two plastic clamps around valve flange and tank flange and tighten just enough so that the valve may be rotated on tank for final positioning.
  - c. Carefully screw pressure gauge (with O'ring in place) into tapped hole in valve body. Do not over-tighten.