

WL-QB Series Underwater Light Operating Instruction

MODEL: WL-QBP100 WL-QBC100 WL-QB-LED072HB/HC
WL-QB-LED009W-PB/PC WL-QB-LED012W-PB/PC

<7> Fill pool until the underwater light is completely submerged in water before operating the light for more than 10seconds. Turn on main switch or circuit breakers, as well as the switch which specially operates the underwater light, to check for proper operation.

⚠ WARNING

- <8> When using, the creepage-protect-switch must be tested at least once per month, to insure the switch natural.
- <9> When using, prohibit any body from stepping on the light, for fear that the distortion of the light makes the lens break up, which may cause accidental injury and loss.

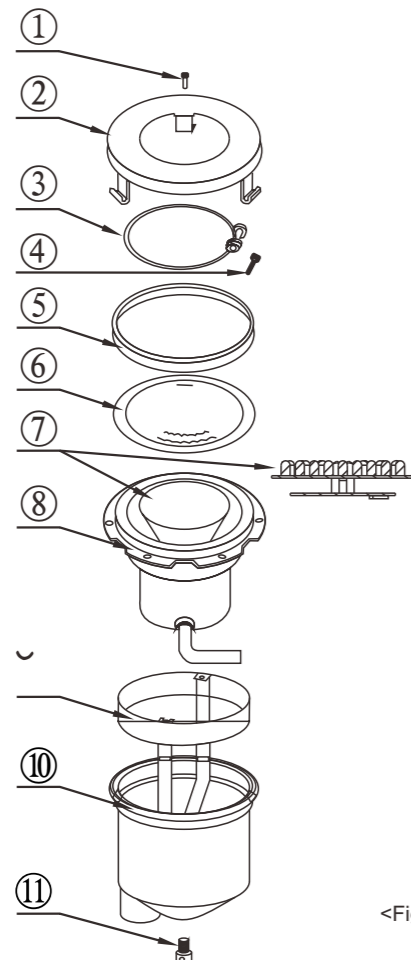
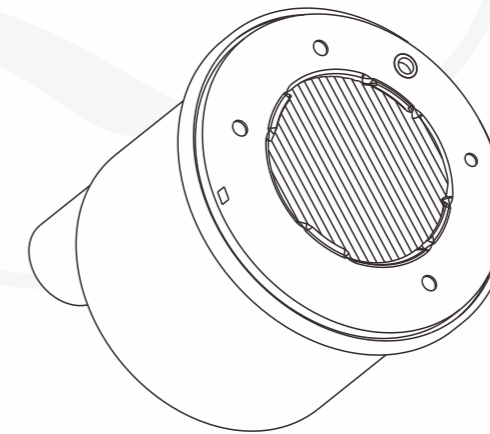
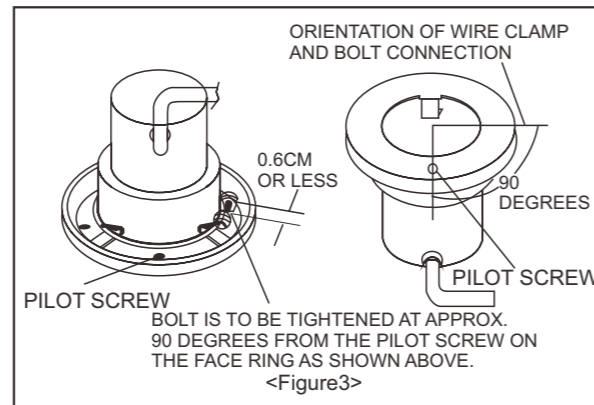
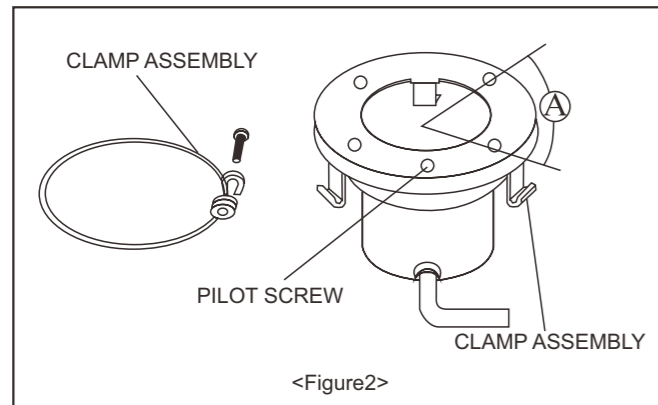

Description		
①	PS01-001	Screws
②	FR01-002	Face ring
③	WS01-002	Clamp assembly
④	B001-002	Screw
⑤	GA01-002	Gasket
⑥	LE01-002	Lens
⑦	FL01-002	Lamp
⑧	NI01-002	Light base
~	GZ01-002	Light mounting block
⑩	DK01-002	Housing
⑪	JD01-002	Grounded lug

⚠ CAUTION

RISK OF ELECTRICAL SHOCK OR ELECTROCUTION

This underwater light must be installed by a licensed or certified electrician in accordance with the national Electrical Code and all applicable local codes and ordinances. Improper installation will create an electrical hazard which could result in death or serious injury to pool users, installer, or other due to electrical shocks, and may also cause damage to property. Read and follow the specific instructions below.

⚠ WARNING

Before installing this underwater light, read and follow all warning notices and instructions accompanying with this light. Otherwise it will result in severe injury, death, or property damage.

⚠ ATTENTION

IMPORTANT NOTICE

This manual contains important information about the installation, operation and safe use of this product. This information should be given to the owner/operator of this equipment.

(Read and Follow all the instructions)

I. Installing light fixture during new pool construction

A. The electrician must complete preparatory steps before light fixture is installed.

See figure 1.

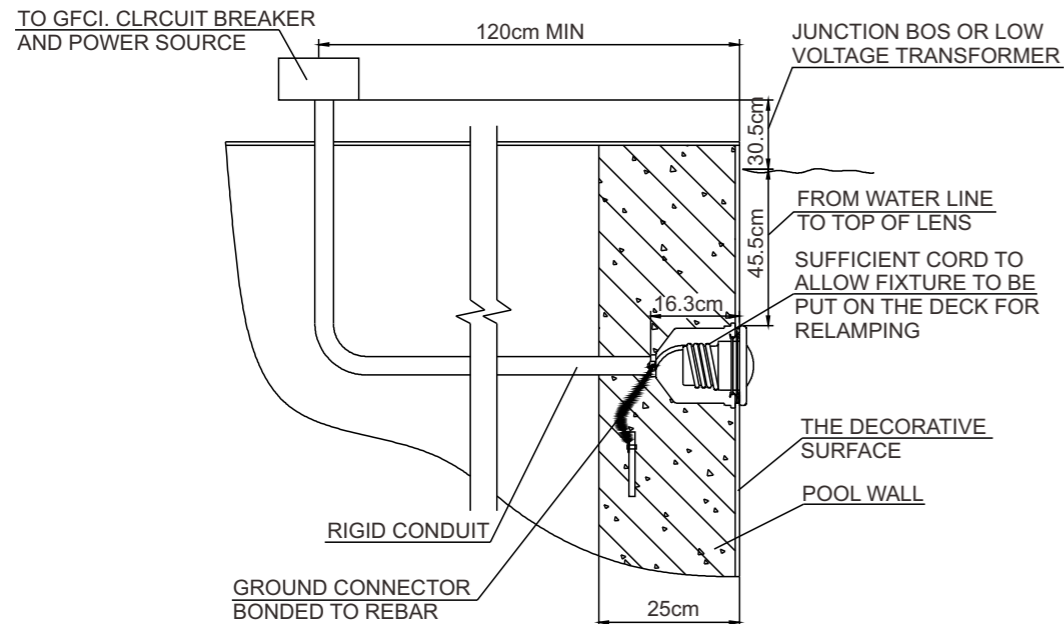

<Figure1>

<1> Ensure that the pool meets the requirements of the current National Electrical Code and all local codes and ordinances. A licensed or certified electrician must install the electrical system to meet or exceed those requirements before the underwater light is installed. Some of the requirements of the National Electrical code which the pool's electrical system must meet are as follows.

- The lighting circuit must have a Ground Fault Circuit Interrupter (GFCI), and must have an appropriately rated circuit breaker.
- The Junction Box (or, for 12 volt models, the low voltage transformer) must be located at least 20cm above water level, at least 10cm above ground level, and at least 120cm from the edge of the pool; see figure 1.
- The light fixture and all metal items within 152cm of the pool must be properly electrically bonded.
- The wet niche must be properly installed so that the top edge of the underwater light's lens is at least 45.5 cm below the surface of the water in the pool; see Figure 1.
- The wet niche must be properly electrically bonded and grounded via the NO.8 AWG ground connector located at the rear of the niche; see Figure 1.

⚠ NOTE

The pool or spa electrical system can be verified with a Pool and Spa Electrical Qualification Test kit. The electrical system inspection using this kit must be performed by trained and certified personnel.

<2> To be certain that pool's electrical system meets all applicable requirements, the electrician should also consult the local building department.

B. Steps to perform after the electrical system requirements are met. See Figure 2.

<1> Feed cord through conduit to Junction Box, leaving at least 120cm of cord the light fixture to coil around the light; see Figure 1. this 120cm of cord around the light allows the light to be serviced after the pool is filled with water.

<2> Cut the cord at the Junction Box, leaving at least 15cm of cord to make connections.

<3> Strip 15cm of the outer cord jacket to expose the three insulated wires. Be careful not to damage the insulation on the three (3) inner wires.

<4> Connect all three (3) wires to the corresponding circuit wires in the Junction Box, and secure the Junction Box cover in place.

⚠ WARNING

Never operate this Underwater Light for more than 10 seconds unless it is totally submerged in water. Without total submersion, the light assembly will get extremely hot, which may result in serious injury to pool users, installer, or bystanders, or in damage to property

<5> Replace the light assembly into niche and tighten special pilot screw.

⚠ WARNING

Use only the special stainless steel pilot screw provided with Underwater Light. Failure to use the screw provided could create an electrical hazard which could result in death or serious injury to pool users, installers or others due to electrical shock.

<6> Fill the pool until the Underwater Light is completely submerged in water before operating the light for more than 10 seconds. Turn on main switch or circuit breaker, as well as the switch which operates the Underwater Light itself, to check for proper operation.

II. Replacing a lamp only

⚠ Notice

Always disconnect power to the pool light at the circuit breaker before servicing the light. Failure to do so could result in death or serious injury to installer, servicemen, pool users, or others due to electrical shock.

<1> Turn off main electrical switch or circuit breaker, as well as the switch which operates the underwater light itself.

<2> You will need the following items: A lamp, see Table 1.

⚠ WARNING

Replace lamp with a similar type and wattage. Failure to replace lamp with the same type of lamp will damage the light assembly and may cause an electrical hazard resulting in death or serious injury to pool users, installers, or others due to electrical shock, and may also cause damage to property.

<3> To remove light assembly, remove the pilot screw at top of face ring, remove light assembly from niche, and place assembly on deck.

<4> Disassemble the light fixture and remove the old bulb, replace the new bulb.

⚠ ADVICE

Because of long-term usage, the gasket will age, which may affect its seal performance, it's better to replace a gasket when replacing lamp every time.

<5> Put the face ring onto the lamp gallbladder firmly, see Figure 2 and 3, and according to the following steps to tighten the screws to ensure a proper seal:

a. Put the round spring seal downwards, let the whole seal tend, put it in the handrail's " U " slot, ensure the seal and the whole handrail completely join together.

b. Join the spring seal's two ends together, insert the bolt into the curve slot (insert it from the whole curve slot to the seal's another end), then revolve the screw. Use the screwdriver to tighten the screw and nut, and the distance between the seal's two ends should be equal to or less than 0.6cm. See Figure3.

<6> Put the lamp body into the lamp holder and tighten the special pilot screw.